

ComREW 100 cable rewinder

New generation rewinding line ComREW 100 is based on the famous Compomec technology. The ComREW 100 is the most suitable for the applications where light weight wire, fiber, tube or similar material need to be rewinded. The unwinder is dancer controlled and the winder is equipped with traverse mechanism. The ComREW 100 is easy to operate, and the latest proven AC-technology ensures long trouble-free and economic lifetime.

The ComREW 100 is easy to equip with many options thanks to the various high tech features:

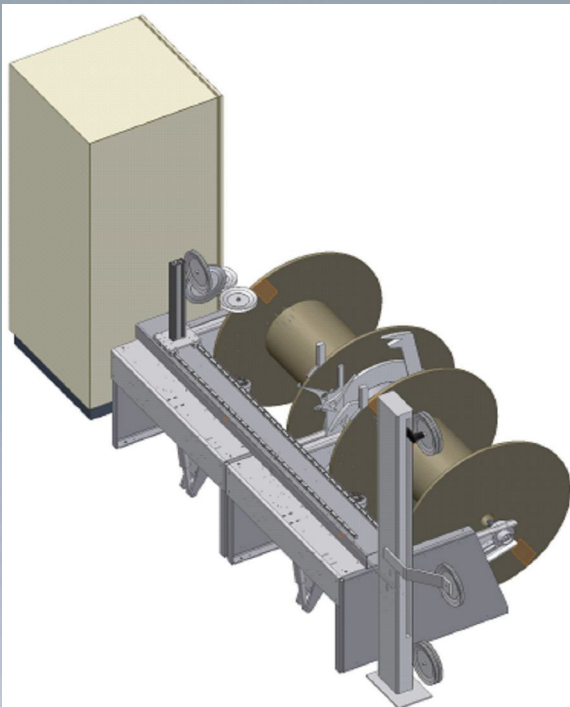

- Forward/backward run
- Cable testing and preparation
- Online length and speed measurement
- Fieldbus connection to line control
- Compact design

SPECIFICATIONS

- Max. reel diameter 100 mm
- Max. reel width 750 mm
- Max. weight 400 kg
- Max. line speed 500 m/min
- Product diameter up to 10 mm
- Min. bending radius 80mm

New generation equipment for optical fiber and cable production. During the past 10 years Compomec has developed and manufactured the equipment for the world leading production lines. Thousands of Compomec equipment have been delivered worldwide in the FO industry. Compomec's innovative and reliable solutions are always one step ahead.

Compomec - "winding the future".

Compomec
CABLE MACHINERY

CONTACT

Sukkulakatu 3
FIN-55120 IMATRA
FINLAND

Int.telephone +358 5 4761 888
Int.telefax +358 5 4761 877
www.compomec.fi
info@compomec.fi