

ComCOL Fiber Colouring Line

The ComCOL colouring and upcoating system is designed for high-speed colouring of optical fibers and versatile upcoating processes with modern UV curable materials.

Machine consists of pay-off unit, coating system with automatic vacuum cleaning system, UV-curing, capstan and single or dual take-up unit all built in one compact frame for small footprint. Coating unit(s) and UV-lamps are located vertically to ensure even layer centricity especially in thick layer upcoating applications.

- single or dual take-up solutions
- versatile UV coating applications

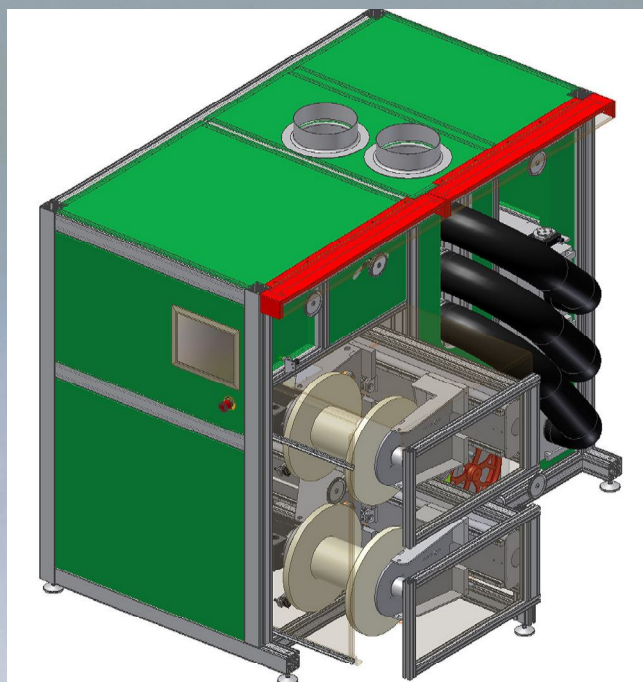

SPECIFICATIONS

- Max. speed 2500 m/min
- Reel dia. max. 350mm
- Ink tank 4 litres
- Fiber tension 0,2-2 N

Compomec provides innovative and reliable solutions to the optical fiber and cable industries including from single wire equipment to the high voltage cable machines. During the past 10 years Compomec has developed and delivered thousands of equipment and solutions worldwide thanks to the co-operation with customers.

Compomec - "winding the future"

Compomec
CABLE MACHINERY

CONTACT

Sukkulakatu 3
FIN-55120 IMATRA
FINLAND

Int.telephone +358 5 4761 888
Int.telefax +358 5 4761 877
www.compomec.fi
info@compomec.fi